

# Liquid Desiccant Systems: A Review

<sup>1</sup>Gaurav Kumar

<sup>1</sup>UG Student

<sup>1</sup>Department of Mechanical Engineering

<sup>1</sup>Cochin University of Science and Technology, Kochi-682022, INDIA

**Abstract:** Desiccant cooling systems have been considered as an efficient method of controlling moisture content in supply air. They do not use any ozone-depleting coolants and consume less energy as compared with the vapor compression systems. In hot and humid areas, the liquid desiccant air-conditioning systems based on evaporative cooling was proposed as an alternative to the traditional vapor compression systems due to its advantage in, removing the air latent load, friendly environment, removing of pollutants from the process air and reduction of the electrical energy. This paper provides an extensive review of liquid desiccant systems (LDSs). All the components of an LDS such as dehumidifier, regenerator, packing material and liquid desiccant properties along with its energy storage capabilities is mentioned. In addition, hybrid of LDSs with sensible cooling technologies is studied. At last, current problems in LDSs are also mentioned.

**Index Terms** - Desiccant cooling systems, dehumidifier, regenerator.

## I. INTRODUCTION

As per a research conducted by International Institute of Refrigeration, energy used by air-conditioning system in household and commercial applications is nearly 45%. Air-conditioning system accounts for 15% of total energy consumption in world [1]. Figure 1 shows electricity distribution in residential and commercial buildings in India. As estimated by International Energy Agency, approximately 22.5 million air coolers were in operation in residential sector only in 2007 [2]. The problem with air-conditioning systems in use is not only that they have less efficiency but also they use refrigerants like CFC, HCFC and HFC, which causes ozone layer depletion. The coolant used to cool water in the evaporator, over the time, leak into the atmosphere and react with ozone layer. CFC have highest global warming potential (GWP) and ozone depleting potential (ODP) and their impact lasts around 45-1700 years on environment.

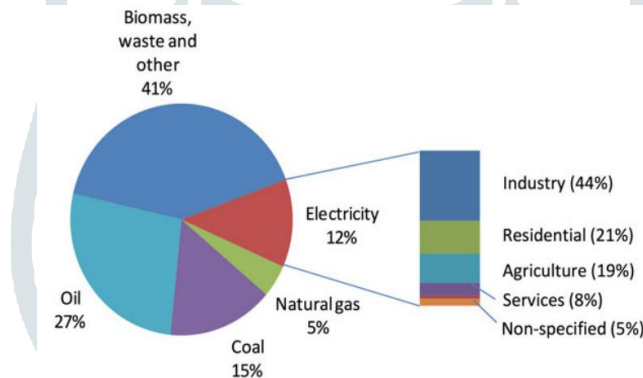

**Fig.1. Total final energy consumption in India in 2007 [2]**

Conventional vapour compression systems (VCSs) simultaneously cools and dehumidifies the air where as a desiccant system only dehumidifies it. Desiccant system can be brought in application with combination of evaporative cooling to maintain the temperature and moisture of air. Energy crisis and air conditioning demand led to increase of research in desiccant system as effective method to fulfill it.

Desiccant system can be categorized on type of desiccant used:

- (1) Liquid Desiccant Systems,
- (2) Solid Desiccant Systems,
- (3) Advanced Desiccants (like, polymeric desiccant, bio-desiccant, etc.)

Solid desiccant include activated silica gel, titanium silicates, alumina, zeolite, etc. whereas liquid desiccant comprises of lithium chloride, lithium bromide, tri-ethylene glycol, calcium chloride, etc.

In this review, liquid desiccant systems have been discussed in detail.

## II. LIQUID DESICCANT SYSTEMS

A simple LDS containing dehumidifier and regenerator is shown in Fig. 2. Moisture from the air is absorbed by the desiccant because of difference in vapour pressure between air and the surface of desiccant solution. Dehumidification takes place until vapour pressure of desiccant reaches equilibrium with air. After dehumidification, air is sent to evaporative cooler to cool down to the required temperature whereas the diluted desiccant solution is sent to the regenerator. Before sending the desiccant directly to the regenerator, it is initially passed through a sensible heat exchanger where its temperature is raised. After that, the liquid is exposed to regenerative air and due to difference in vapour pressure; the moisture is transferred from solution to air. Now this concentrated solution is again passed through heat exchanger and a cooling coil before it is sent to dehumidification unit. Here, heat exchangers are used to pre-heat the weak solution and pre-cool the strong solution.

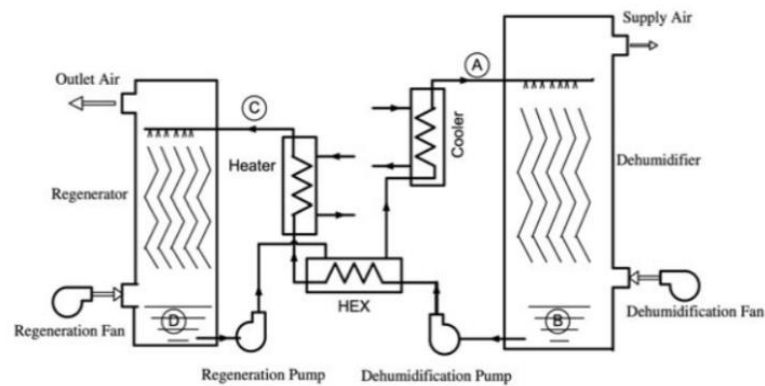

Fig.2. Schematic of an LDS [3]

The typical cycle of the desiccant is shown in Fig. 3.

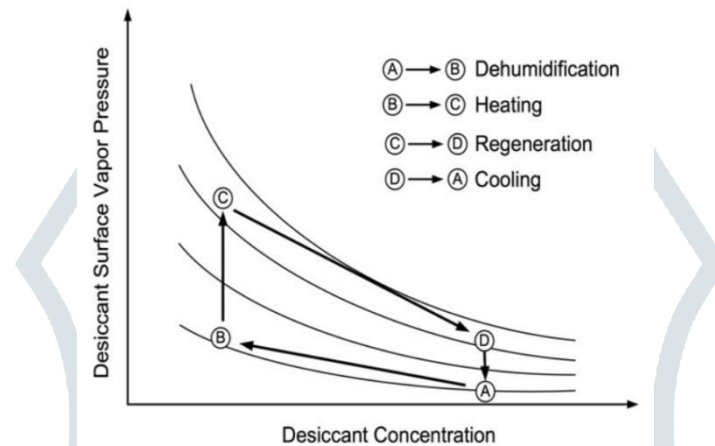

Fig.3. Desiccant dehumidification and regeneration process [3]

### III. LIQUID DESICCANT PROPERTIES

As far as LDSs are concerned, liquid desiccants are the most important part of the system. There are various properties which determine its potential to be used in a desiccant cooling system. Properties include conductivity, dynamic viscosity, specific heat capacity, density, boiling point elevation, regeneration temperature, etc. Among all the properties, surface vapour pressure is one of the most important parameters that is responsible for heat and mass transfer in dehumidifier [4]. Moreover, liquid desiccants are generally odour-less, non-toxic, non-flammable and inexpensive. Lithium chloride (LiCl), lithium bromide (LiBr) and calcium chloride ( $\text{CaCl}_2$ ) are some of the most commonly used liquid desiccants. Among all three salts,  $\text{CaCl}_2$  is more economic and on the other hand LiCl is more stable [4].

Performance of two commonly used liquid desiccants namely LiCl and LiBr was compared by Liu et. al. They concluded that under similar desiccant volumetric flow rates, lithium chloride (LiCl) is better dehumidifier than lithium bromide (LiBr) as it has lower vapour pressure and therefore, regeneration performance of lithium bromide (LiBr) is better than lithium chloride (LiCl). Also, since all the aqueous solutions are highly corrosive therefore any carry-over during dehumidification may cause adverse effects on occupant's health [5].

A new desiccant potassium formate (HCOOK) is less corrosive as compared with other aqueous salts and has a negative crystallization temperature and cheaper than others [6]. A novel air dehumidifier was investigated by Qiu et al. using potassium formate. When a highly concentrated solution was taken then it was able to effectively dehumidify the air with high moisture content (75% RH) but at same time it was poor in dehumidifying low moisture air (43% RH) [7].

Some of the major advantages and disadvantages of liquid desiccant was pointed out by Baniyounes et al. [8]. They are as follows:

#### Advantages

- (1) LDSs are suitable for use with low regeneration temperature because of low-pressure drop across it.
- (2) The ability to pump liquid desiccants makes the entire unit small and compact.
- (3) Liquid desiccants can be stored and used when heat source for regeneration is not available.

#### Disadvantages

- (1) Corrosive nature of all liquid desiccants like lithium chloride, lithium bromide and others is a major threat for liquid desiccant system.
- (2) Any carry-over of liquid desiccant along with air supply can cause serious issues to occupant's health.
- (3) Desiccants of aqueous salts get crystallized.

In dehumidification, the mass concentration is selected in such a way that vapour pressure of desiccants is less than air to be processed for effective heat and mass transfer. Higher concentration is more favorable for dehumidification process. But corrosive nature increases with higher concentration and it can damage storage tank and desiccant unit air outlet. Thus, an optimum range of concentration is selected for different liquid desiccants. It is mentioned in the Table 1 below [9].

Table. 1

Liquid Desiccant	Concentration Range (%)
Lithium chloride	30-36*
Lithium bromide	45-55
Potassium formate	65-70

\*Temperature in the range of 30-35 degree Celsius.

IV. DEHUMIDIFICATION

The process of heat and mass transfer from the inlet air to liquid desiccant takes place in the dehumidifier, while the temperature difference leads the heat transfer between the air and desiccant solution. Vapour pressure difference drives the mass transfer between air and desiccant. Commonly used dehumidification units include are finned-tube surface, coil-type absorber, spray tower and packed tower [10]. Dehumidification unit can be classified into two types based on heat extraction process; they are adiabatic dehumidifier and internally cooled dehumidifier. Fig. 4 shows two vertical spray towers with and without internal cooling unit [11].

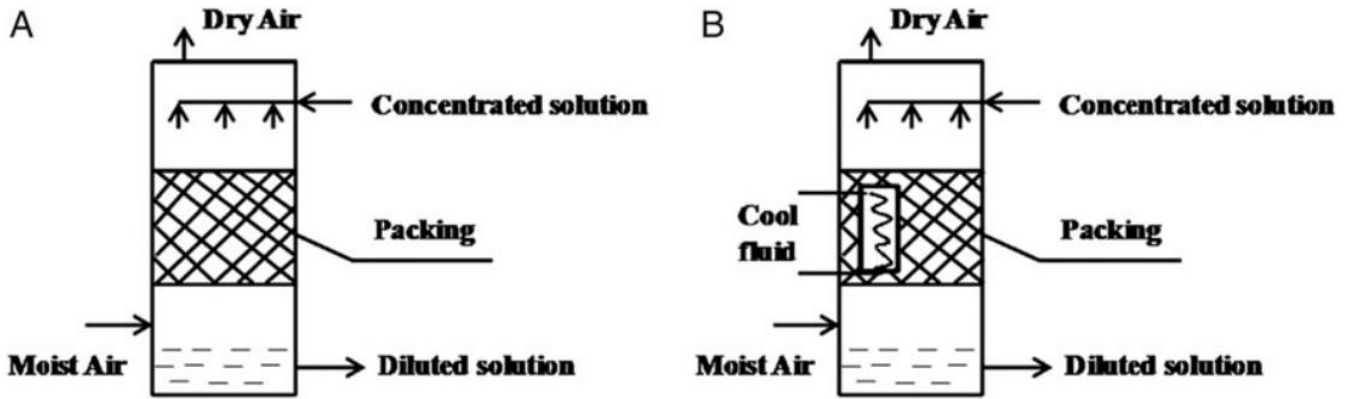

Fig.4. (A) Adiabatic dehumidifier, (B) internally cooled dehumidifier [11]

Xiong and his colleagues developed a two-stage liquid desiccant cooling system using an exergy analysis. In this type of dehumidification process, process air has to pass through two-dehumidification units. Inlet air is passed through calcium chloride solution followed by a lithium chloride solution. The main advantage of pre-dehumidification process using calcium chloride is that it helps in reducing irreversibility in the dehumidification process. On the other hand, during regeneration lithium chloride is regenerated first followed by calcium chloride. It is because regeneration ability of calcium chloride is higher than that of lithium chloride. Results showed that the thermal co-efficient performance of the proposed system was 0.73 whereas exergy efficiency was 23%. Additionally, the energy storage capacity of the desiccant solutions showed considerable improvement over single-stage dehumidification [12].

A packing material is a medium for liquid desiccant to interact with the process air stream to extract moisture. A packing material must be inert to liquid desiccants. Packing materials and their configuration significantly influence the performance of dehumidification unit of the desiccant cooling system. They are broadly classified as regular/ structured packing and random packing based on their configuration. Regular packing increases the performance of the dehumidifier by providing low-pressure drop for the air stream and is easy to install as compared with random packing. It also reduces the liquid desiccant resistance in the dehumidification unit. On the other hand, random packing material cannot adjust to the variation in liquid desiccant flows and results in uneven distribution of the desiccant solution over the surface of the packing material, which reduces the performance of the dehumidification system. However, regular packing is costlier than random packing [4, 13].

Fig. 5 shows the flow patterns of the humid air and liquid desiccant. There are three common flow patterns in an adiabatic dehumidifier namely parallel flow, cross-flow and counter flow. Flow patterns determine the contact area and the process of interaction between desiccant and inlet air. Flow patterns also determine the type of mathematical model that is suitable for a particular desiccant system. Liu and his colleagues prepared analytical solutions of dehumidifier and regenerator based on the type of flow using mathematical models from existing research. Analytical solutions of all the cases are in good agreement with the experimental results from other researches [14].

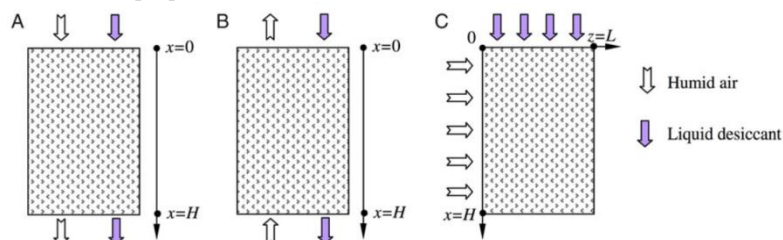
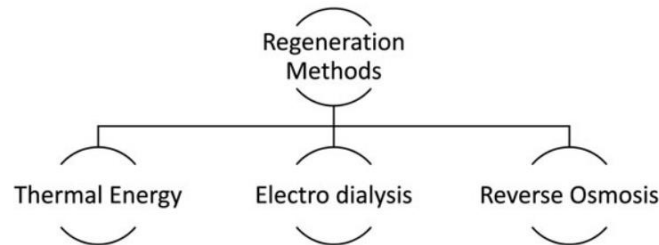

Fig.5. Flow patterns of air and liquid desiccant in dehumidification unit [15]

## V. REGENERATION

A regenerator is a unit that is used to convert the weak or diluted desiccant solution into concentrated solution as shown in Fig. 2. Regenerator is similar to the dehumidifier, however, the basic function and process of the two units is opposite to each other. Another difference is that a dehumidifier unit has a superfluous layer of insulation to reduce the heat and mass transfer from the atmosphere. Regenerator is usually an adiabatic unit. However, Yin and his colleagues showed that as the regeneration process continues the temperature of liquid desiccant reduces and solution cannot provide latent heat of vaporization required to transfer water present in the solution to the incoming air. Thus, the performance of the system reduces. Therefore, they proposed an internally heated regenerator in which a heating coil provides heat energy to maintain the solution temperature [16]. Regeneration process using thermal energy is the most common method. However, there are some other methods for regeneration as shown in Fig. 6. They are as follows:



**Fig. 6. Various methods of regeneration**

Cheng and his fellow researchers experimentally investigated the performance of an electro dialysis regenerator for liquid desiccant. In electro dialysis process, ions are transported through a selective membrane under the effect of electric field. A parametric analysis of electro dialysis regenerator was performed based on current utilization and solution mass transfer rate per unit area of anion exchange membrane. Results showed that maximum current utilized by the system was 55%. Additionally, increase in desiccant flow rate increases the mass flow rate and current utilization by strong solution [17].

Reverse osmosis is commonly used for desalination of seawater. Similarly, weak solution can be converted into a strong solution by removing the added water from the desiccant [18]. In this process, an MFI zeolite membrane was used by Al-Sulaiman and his colleagues to separate the weak calcium chloride solution from the water. They proposed this method for countries like Saudi Arabia where there is a scarcity of soft water. They combined this method of regeneration with a two-stage evaporative cooling in which water needed by the evaporative coolers was supplied by the reverse osmosis [18].

## VI. HYBRID LIQUID DESICCANT AC SYSTEMS

Liquid desiccant systems are suitable for extracting latent heat from the air. However, a desiccant cooling system is incapable of removing sensible heat from the air. Therefore, desiccant systems are often used in combination with direct or indirect evaporative cooling system, vapour compression refrigeration system or vapour absorption system to remove latent and sensible heat before introducing into the space. A brief review of the systems shown in Fig. 7 is as follows:

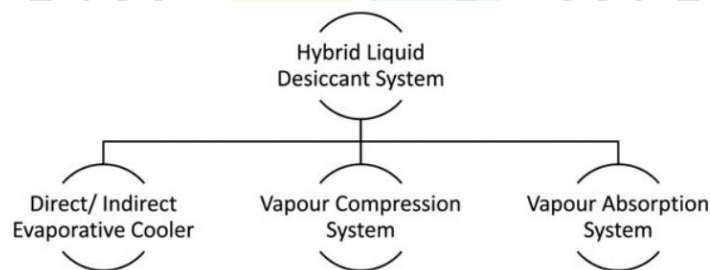

**Fig.7. Hybrid of LDS with various systems.**

## VII. CURRENT PROBLEMS

Although desiccant systems have proven to be more efficient and environmentally friendly than conventional VCSs, desiccant systems have some drawbacks and problems. Solving these problems would make them more competitive in the market. Major problems involve reverse dehumidification, desiccant unit corrosion, desiccant carry-over. Additionally, conventional air conditioners come in compact sizes. But, the desiccant systems combined with an evaporative cooler are usually bulky [4]. Research has shown some considerable solutions. Reverse dehumidification occurs when process air is humidified instead of dehumidification. Reverse dehumidification can occur even when the vapour pressure of liquid desiccant is positive [19]. The problem of corrosion is solved by using plastic material in the dehumidification unit and the storage tank. Carry-over occurs when particles of desiccant solution mix with the process air. In indoor spaces, carry-over can be harmful for the health of occupants and can lead to the corrosion of ducts and pipes near air outlet. One solution to this problem is to introduce micro-porous membrane. Allowing moisture transfer through these semipermeable membranes would prevent interaction between the process air and liquid desiccant [20]. Additionally, it also provides a distinct and constant surface area which would be free of air and desiccant flow rates and would inhibit the advance of microbes in the working conditions due to low moisture content on membrane-air interface [20, 21].

Das and Jain did an experimental investigation using micro-porous semipermeable hydrophilic membranes as desiccant cores to reduce the carry-over of liquid desiccant in supply air. Lithium chloride was used as a liquid desiccant to test membrane contractors developed from hydrophobic PP, PVDF and Tyvek membranes. The results indicated that although the problem of carry-over was controlled, dehumidification effectiveness was low varying between 23% and 45%, as membranes create additional resistance [22]. Kumar and his colleagues proposed a simulation and parametric study of two innovative individual liquid desiccant cycles. Both the cycles used multiple absorbers based on falling film design. Falling film-based absorber was chosen as it has low-pressure drops. Proposed cycles not only improved the coefficient of performance of the system but also controlled the problem of carry-



over when operated at higher concentration of desiccant solution [19]. Another problem is the crystallization of liquid desiccant. Crystallization can occur in a liquid desiccant solution stored at high concentration with decrease in temperature [4].

Ge and his colleagues did a comparison study between experimental data and; heat and mass transfer model for membrane-based dehumidifier and regenerator. The results showed that the predicted results from the model agreed with the experimental results of the dehumidifier. However, the model did not hold agreement with the regenerator experiment results. Discrepancies between the model and experimental data were caused by the crystallization of lithium chloride aqueous solution in the openings of membrane during the regeneration process. These crystals reduced the moisture transfer and consequently produced errors in experimental data [23].

### VIII. CONCLUSIONS

Desiccant cooling systems were reviewed in this communication. Conclusions derived from the review are as follows:

- (1) Desiccant cooling systems do not use any ozone-depleting refrigerants. Moreover, they can operate successfully on low-grade heat from solar energy, combined heat and power plant or waste heat from factories or chimneys.
- (2) Lithium chloride and calcium chloride are the most commonly used desiccants. Lithium chloride is popular because of low vapour pressure and stability while calcium chloride is cheap and easily available. However, both the salts are corrosive nature and require precaution before use. Among all the aqueous salts, potassium formate is least corrosive and can be used as a viable replacement.
- (3) Internally cooled dehumidification units help to reduce the heat discharge and allow lower flow rates, which can improve the performance of the system. Two-stage dehumidification unit can help to reduce the irreversibility in the dehumidification process and improves the storage capacity of the desiccant solutions.
- (4) Type of packing material selected for dehumidification core is important. Structured packing allow lower pressure drop than random packing but is expensive. On the other hand, random packing material has lower performance because of uneven distribution of liquid desiccant. In dehumidifier core airflow resistance decreases with increase in void ratio. Mass transfer performance increases with the increase in wetted area.
- (5) Liquid desiccant can be regenerated using thermal energy either by heating the weak solution or heating the regeneration air using air – water heat exchanger.
- (6) Using thermal energy to regenerate the liquid desiccant is not the only option. It can also be done with the help of electro dialysis or reverse osmosis depending on the conditions and suitability.
- (7) An adiabatic desiccant system is mostly suitable for drying the air. If cooling is required, then a hybrid system has to be used. A LDS combined with a VCS has a high coefficient of performance.
- (8) It can also be combined to an evaporative cooler direct or indirect. A hybrid LDS does not require any refrigerants and thus is more environmentally friendly.
- (9) There are concerns that require several design optimizations like carry-over of liquid desiccant at high flow rates, reverse dehumidification at low air humidity ratios and corrosion of the dehumidification unit and storage tank in case of any leakages. Many researches have suggested that the problem of carry-over can be by using micro-porous membrane, which would only allow the air to pass and not the liquid desiccant. However, such membrane also increases the mass transfer resistance.

### REFERENCES

- [1] Choudhury B, Chatterjee PK, Sarkar JP. Review paper on solar-powered air-conditioning through adsorption route. *Renew Sustain Energy Rev*2010;14: 2189 – 95.
- [2] Remme U, Trudeau N, Graczyk D, et al. Technology Development Prospects for the Indian Power Sector. International Energy Agency [IEA], 2011.
- [3] Wang XL, Cai WJ, Lu JG, et al. A hybrid dehumidifier model for real-time performance monitoring, control and optimization in liquid desiccant de-humidification system. *Appl Energy*2013;111:449 – 55.
- [4] Mei L, Dai YJ. A technical review on use of liquid-desiccant dehumidification for air-conditioning application. *Renew Sustain Energy Rev*2008;12:662 – 89.
- [5] Liu XH, Yi XQ, Jiang Y. Mass transfer performance comparison of two commonly used liquid desiccants: LiBr and LiCl aqueous solutions. *Energy Conversion Manag*2011;52:180 – 90.
- [6] Afonso CFA. Recent advances in building air conditioning systems. *Appl Therm Eng*2006;26:1961 – 71.
- [7] Qiu GQ, Riffat SB. Experimental investigation on a novel air dehumidifier using liquid desiccant. *Int J Green Energy*2010;7:174 – 80.
- [8] Baniyounes AM, Ghadi YY, Rasul MG, et al. An overview of solar assisted air conditioning in Queensland's subtropical regions, Australia. *Renew Sustain Energy Rev*2013;26:781 – 804.
- [9] Patil KR, Tripathi AD, Pathak G, et al. Thermodynamic properties of aqueous-electrolyte solutions.1. vapor-pressure of aqueous-solutions of LiCl, LiBr, and LiI. *J Chem Eng Data*1990;35:166 – 8.
- [10] Mandegari MA, Pahlavanzadeh H. Introduction of a new definition for effectiveness of desiccant wheels. *Energy*2009;34:797 – 803.
- [11] Luo YM, Yang HX, Lu L, et al. A review of the mathematical models for predicting the heat and mass transfer process in the liquid desiccant dehumidifier. *Renew Sustain Energy Rev*2014;31:587 – 99.
- [12] Xiong ZQ, Dai YJ, Wang RZ. Development of a novel two-stage liquid desiccant dehumidification system assisted by CaCl<sub>2</sub> solution using exergy analysis method. *Appl Energy*2010;87:1495 – 504.
- [13] Kumar R, Asati AK. Simplified mathematical modeling of dehumidifier and regenerator of liquid desiccant system. *Int J Curr Eng Technol* 2014;4:557 – 63.
- [14] Liu XH, Chang XM, Xia JJ, et al. Performance analysis on the internally cooled dehumidifier using liquid desiccant. *Build Environ*2009;44:299– 308.
- [15] Liu XH, Jiang Y, Xia JJ, et al. Analytical solutions of coupled heat and mass transfer processes in liquid desiccant air dehumidifier/regenerator. *Energy Conver Manag*2007;48:2221 – 32.
- [16] Yin YG, Zhang XS, Peng DG, et al. Model validation and case study on internally cooled/heated dehumidifier/regenerator of liquid desiccant systems. *Int J Thermal Sci*2009;48:1664 – 71.

- [17] Cheng Q, Xu Y, Zhang XS. Experimental investigation of an electro dialysis regenerator for liquid desiccant. *Energy Build*2013;67:419 – 25.
- [18] Al-Sulaiman FA, Gandhidasan P, Zubair SM. Liquid desiccant based two-stage evaporative cooling system using reverse osmosis (RO) process for regeneration. *Appl Therm Eng*2007;27:2449 – 54.
- [19] Kumar R, Dhar PL, Jain S,et al. Multi absorber standalone liquid desiccant air-conditioning systems for higher performance. *Solar Energy* 2009;83: 761 – 72.
- [20] Jain S, Tripathi S, Das RS. Experimental performance of a liquid desiccant dehumidification system under tropical climates. *Energy Conver Manag* 2011;52:2461 – 6.
- [21] Isetti C, Nannei E, Magrini A. On the application of a membrane air-liquid contactor for air dehumidification. *Energy Build*1997;25:185 – 93.
- [22] Das RS, Jain S. Experimental performance of indirect air-liquid membrane contactors for liquid desiccant cooling systems. *Energy*2013;57:319 – 25.
- [23] Ge GM, Moghaddam DG, Abdel-Salam AH,et al. Comparison of experimental data and a model for heat and mass transfer performance of a liquid-to-air membrane energy exchanger (LAMEE) when used for air de-humidification and salt solution regeneration. *Int J Heat Mass Transfer* 2014;68:119 – 31.

